

C30C/C30A

Basic systems 30 Watt

C-series products, CO₂ vector lasers for industrial use, are available for high-quality laser marking. Mark your products permanently and flexibly, either while stationary or during movement of the product (MOTF), and you benefit from innovative technology from a single source.

Advantages

- Designed for high line speeds (=short cycle times)
- Minimal servicing and maintenance costs
- Windows-based operator interface with graphics preview
- Ultra-easy integration in production plants and open interfaces

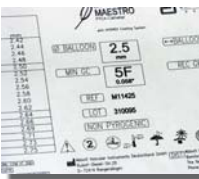

C30C/C30A

Basic systems 30 Watt

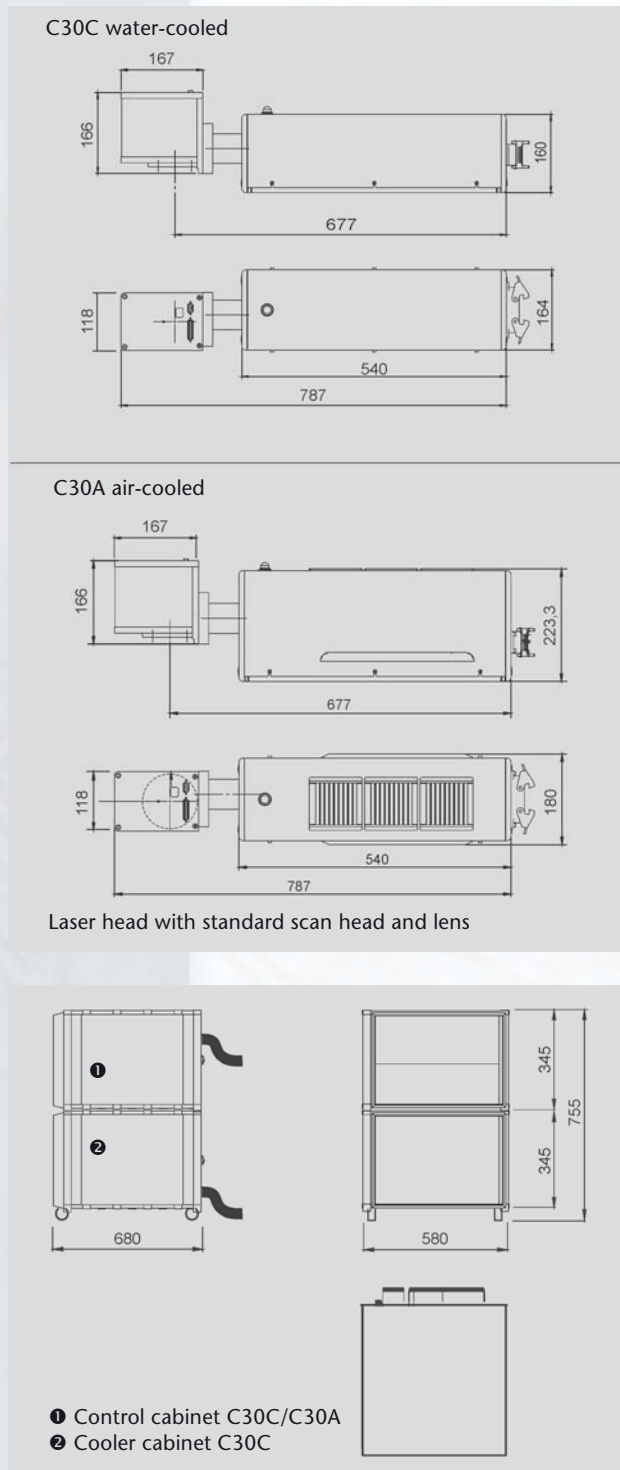

System

Marking field	140 x 140 mm ² (f=200 mm)
Marking speed	up to 400 m/min up to 1000 characters/s
Line width	200 µm (optionally 100 µm)

Laser

Laser type	Sealed-off CO ₂ -Laser, 10600 nm
Power (CW)	typical 30 W
Power stability	+/- 5 % (CW)
Output modes	Continuous wave operation (CW) Pulsed operation (QS, 0.3 - 25 kHz)
Life time	approx. 30,000 h expected

Control

PC	CompactPCI-PC
Operating system	MS Windows XP
Laser control	FOBAGRAF with Import functions of plt/dwg/dxf/ai/jpg/tif/pcx/bmp ...
Interfaces	serial, digital I/O, Ethernet, USB Product timing sequence, speed recognition

Installation

Electrical	1/N/PE, AC 230 V, ± 10%, 50/60 Hz
Power consumption	typical 1.2 kW ¹⁾ / 1.0 kW ²⁾
Cooling	Water/air cooler ¹⁾ Air ²⁾
Temperature	5 - 38 °C
Humidity	90 % (up to max. 20 °C) 30 % (up to max. 38 °C) non-condensing
Weight	Laser head approx. 15 kg ³⁾ Control cabinet approx. 60 kg ¹⁾²⁾⁴⁾ Cooler cabinet approx. 60 kg ¹⁾⁴⁾
Degree of protection	Control-/Cooler cabinet IP 43 (IP54 ⁵⁾) Laser head IP 54
Safety	Class IV Laser

Options

Marking on the fly	for marking moving workpieces
Changeable lens	100 mm/ 250 mm/ 300 mm/ 435 mm
Suction filter	

- ¹⁾ C30C water-cooled
- ²⁾ C30A air-cooled
- ³⁾ without F-Theta lens
- ⁴⁾ with OEM-Components
- ⁵⁾ optionally

FOBA®

Laser Marking + Engraving

A Virtek Company

EUROPE

FOBA Technology + Services GmbH
www.foba.de
sales@foba.de

Altenaer Straße 170
D-58513 Lüdenscheid
Germany

Tel. +49 23 51 996-0
Fax +49 23 51 996-155

NORTH & SOUTH AMERICA

Virtek
www.virtek.ca
fobasales@virtek.ca

785 Bridge Street
Waterloo, ON N2V 2K1
Canada

Tel. +1 800 684-7835 or 519 746-7190
Fax +1 519 746-3383

GREECE

em-pi-es
www.em-pi-es.com
info@em-pi-es.com

Nausis 77, Evosmos
56224 Thessaloniki

Tel. +30 2310 7780-83
Fax +30 2310 7780-65
Tel. +30 210 6856-562 (Athens)

 **em·pi·es**
Master·Part·Systems

Your local agency