

DP20GS/DP30GS

Basic systems 16 W/20 W

The DP20GS and DP30GS end-pumped high-end systems are ideal for use when optimal laser beam quality and performance are required. They are especially suitable in the field of card and passport personalisation, in particular for the marking of ID cards with grey scale images, as well as for lacquer removal to create day and night design.

Advantages

- Output power 15 Watt and 20 Watt (CW)
- Excellent laser beam quality and pulse-to-pulse stability.
- Single-phase mains connection
- No external cooling water
- Long working life of the laser diodes means little servicing

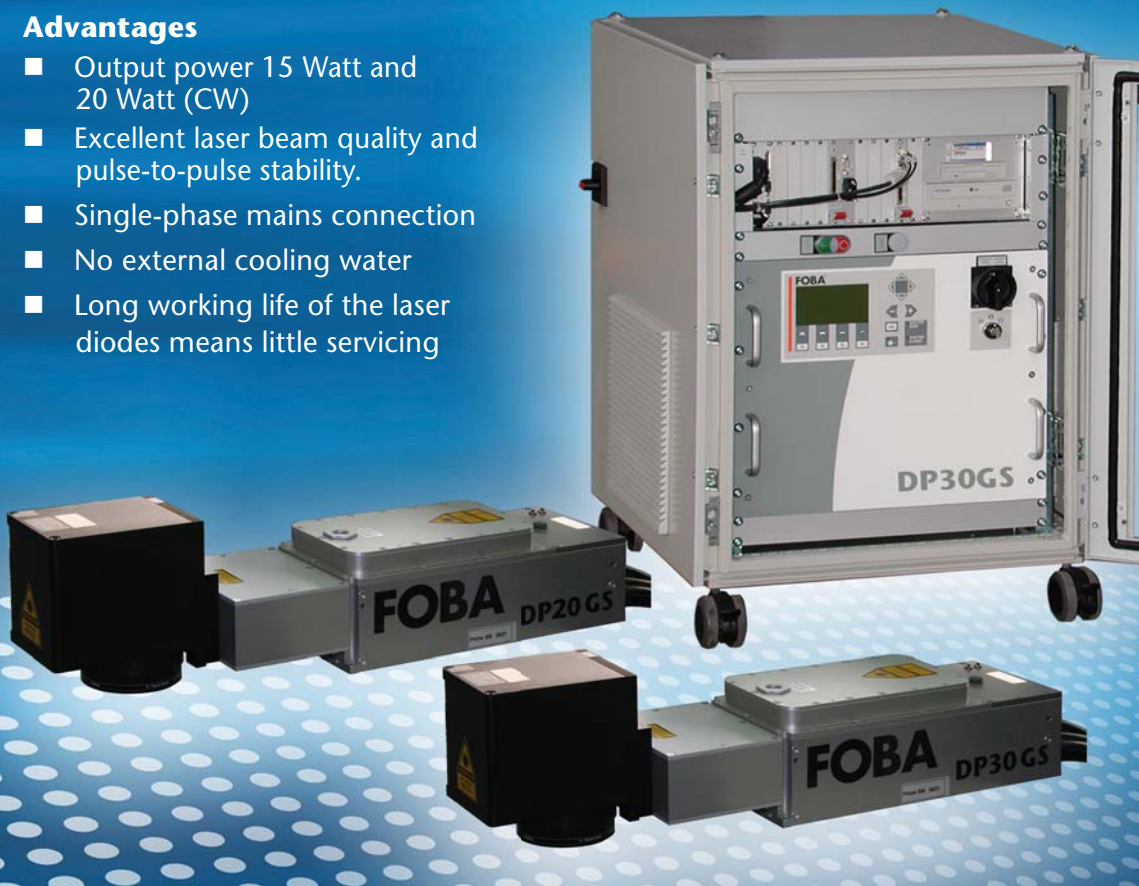

DP 20GS/DP30GS

Basic systems 16 W/ 20 W

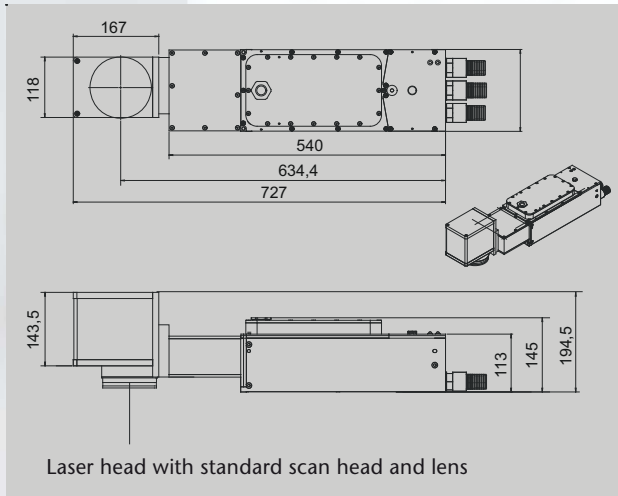

Laser head with standard scan head and lens

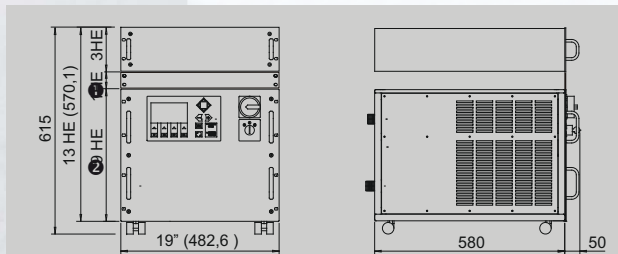

OEM components

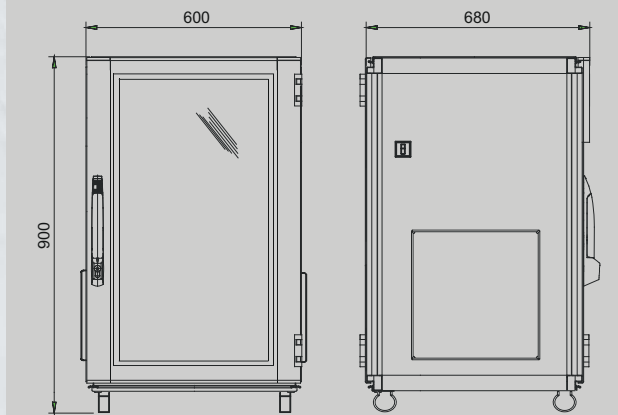

Control cabinet

System

	DP20GS	DP30GS
Marking field	110 x 110 mm ² (f=160 mm)	
Marking speed	up to 5000 mm/s up to 500 characters/s	
Line width	typically 70 µm	

Laser

Laser type	Nd:YVO ₄ , 1064 nm, diode pumped	
Power (CW)	typically 16 W	typically 20 W
(QS)	typically 30 kW/ pulse (30 kHz)	typically 25 kW/ pulse (40 kHz)
Power stability	+/- 1 % (CW) +/- 2 % (QS)	
Output modes	Continuous wave operation (CW) Pulsed operation (QS, 10/25 - 100 kHz) Mixed operation (parameterizable)	
Pulse energy	0.5 mJ (20 kHz)	0.5 mJ (40 kHz)
Pulse width	12 ns (20 kHz)	20 ns (40 kHz)

Control

PC	CompactPCI-PC
Operating system	MS Windows XP
Laser control	FOBAGRAF with Import functions of plt/dwg/dxf/ai/jpg/tif/pcx/bmp ...
Interfaces	serial, digital I/O, Ethernet, USB

Installation

Electrical	1/N/PE, AC 230 V, ± 10%, 50/60 Hz
Power consumption	typically 1.6 kW
Cooling	internal water/air cooler
Temperature	15 - 40 °C
Humidity	90 % (up to max. 20 °C) 30 % (up to max. 40 °C) non-condensing
Weight	Laser head approx. 15 kg ¹⁾ OEM components approx. 80 kg Control cabinet approx. 150 kg ²⁾
Degree of protection	Control cabinet IP54 Laser head IP 54
Safety	Class IV Laser

Options

Marking on the fly	for marking moving workpieces
19"-Racks	for integration
Changeable lens	100 mm/163 mm/254 mm/420 mm
High-speed-scan heads	

¹⁾ without F-Theta lens

²⁾ with OEM components

FOBA®

Laser Marking + Engraving

A Virtek Company

EUROPE

FOBA Technology + Services GmbH
www.foba.de
sales@foba.de

Altenaer Straße 170
D-58513 Lüdenscheid
Germany

Tel. +49 23 51 996-0
Fax +49 23 51 996-155

NORTH & SOUTH AMERICA

Virtek
www.virtek.ca
fobasales@virtek.ca

785 Bridge Street
Waterloo, ON N2V 2K1
Canada

Tel. +1 800 684-7835 or 519 746-7190
Fax +1 519 746-3383

GREECE

em-pi-es
www.em-pi-es.com
info@em-pi-es.com

Nausis 77, Evosmos
56224 Thessaloniki

Tel. +30 2310 7780-83
Fax +30 2310 7780-65
Tel. +30 210 6856-562 (Athens)

 **em·pi·es**
Master·Part·Systems

Your local agency