

G5

Laser engraving machine

Die G5 is our All-round talent for marking and engraving. It is equipped with an automatically height-adjustable laser head and can be expanded to 5 axes. According to individual request, the machine can be delivered with pneumatic lifting door, rotary table or 2 large swing doors.

Advantages

- Marking and engraving of 2D and 3D structures, contours and surfaces
- Contact-free processing - no need to clamp the workpieces
- Software for marking, engraving, measuring and moving the axes



G5

Laser engraving machine

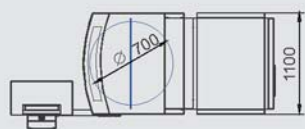
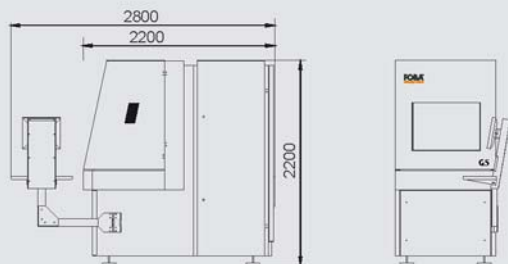

version lifting door/rotary table

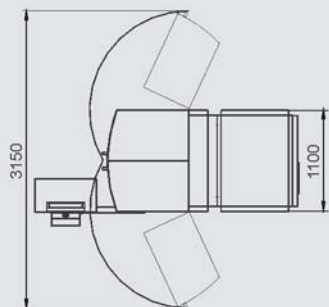
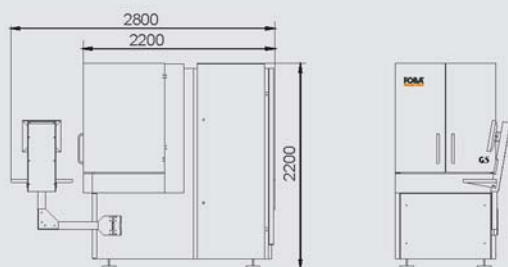

version swing door

Machine

Load	Workpieces up to 100 kg ¹⁾²⁾ 16 kg (8 kg per station) ³⁾
Z-axis (focus)	up to 500 mm
Engraving field	120 x 120 mm ² (f=163 mm)
Jog Dial	Manual operation for all axes

Control

AC servo motors	with digital control system
Path control	up to 5 axes
Laser control	FOBAGRAF
Machine control	FobaEMC
Operating system	MS Windows 2000 / XP

Laser

Laser type	1064 nm, up to 100 Watt
Output modes	Continuous wave operation (CW) Pulsed operation (QS) 0.5 - 100 kHz Mixed operation (parameterizable)

Options

Touch probe	For setting up workpieces
Tactile probe	Depth measurements
Pointer	Adjustment aid
IMP	Vision-based mark positioning
X/Y cross table ¹⁾³⁾	Table plate 250 x 250 [mm] Travel 500 x 500 [mm]
Turn-swivel unit ¹⁾³⁾	360°, +90° 360°, +90°/-45°
Suction filter	
Water/air cooler	optionally to Water/water cooler

Installation

The way the unit is set up depends on the design of the working area and the integrated laser system.

Electrical	3/N/PE, AC 400V, 50/60 Hz
Power consumption	2.8 - 8 kVA ⁴⁾
Temperature	15 - 40 °C
Humidity	90 % (up to max. 20 °C) 30 % (up to max. 40 °C) non-condensing
Weight	Machine approx. 800 kg
Degree of protection	IP 54
Safety	Laser class 1

- ¹⁾ version lifting door
- ²⁾ version rotary table
- ³⁾ version swing door
- ⁴⁾ depends on the basic system

FOBA®

Laser Marking + Engraving

A Virtek Company

EUROPE

FOBA Technology + Services GmbH
www.foba.de
sales@foba.de

Altenaer Straße 170
D-58513 Lüdenscheid
Germany

Tel. +49 23 51 996-0
Fax +49 23 51 996-155

NORTH & SOUTH AMERICA

Virtek
www.virtek.ca
fobasales@virtek.ca

785 Bridge Street
Waterloo, ON N2V 2K1
Canada

Tel. +1 800 684-7835 or 519 746-7190
Fax +1 519 746-3383

GREECE

em-pi-es
www.em-pi-es.com
info@em-pi-es.com

Nausis 77, Evosmos
56224 Thessaloniki

Tel. +30 2310 7780-83
Fax +30 2310 7780-65
Tel. +30 210 6856-562 (Athens)



Your local agency

